

**J.A.S.**  
MOTORSPORT



**HRC**  
Honda RACING

  
**HONDA**

**CIVIC TYPE R**



JAS

Honda RACING

TYPE R

TCR

HRC  
HONDA RACING

TYPE R

PIRELLI

PIRELLI

Honda RACING

OMP

JAS

# INDEX

<b>R</b> BODYWORK	1
<b>R</b> CHASSIS	2
<b>R</b> ENGINE AND SYSTEMS	3
<b>R</b> ENGINE CONTROL / HARNESS AND CONTROLS	4
<b>R</b> DISPLAY AND DATA LOGGING	5
<b>R</b> GEARBOX SADEV	6
<b>R</b> FRONT SUSPENSION	8
<b>R</b> REAR SUSPENSION	9
<b>R</b> BRAKING SYSTEM	10
<b>R</b> FUEL SYSTEM	11
<b>R</b> INTERIOR EQUIPMENT	12
<b>R</b> INTERIOR EQUIPMENT (OPTIONALS)	13
<b>R</b> ENDURANCE BRAKES (OPTIONALS)	14
<b>R</b> ENDURANCE FUEL SYSTEM (OPTIONAL)	15
<b>R</b> DRIVER OVERALLS / BESPOKE CAR LIVERY	16
<b>R</b> SERVICES	17
<b>R</b> SALE CONDITIONS	18



## BODYWORK

- R** Brand-NEW CFD exterior design and aerodynamics
- R** Front/rear carbon fenders
- R** Front/rear carbon bumper
- R** Carbon side skirts
- R** Bonnet openings trims
- R** Carbon front splitter
- R** J.A.S. rear wing and fixings
- R** Front composite inner arch liners



# CHASSIS

- R** TIG welded roll cage in chrome-molybdenum steel
- R** Seam welding of body panels and chassis rails
- R** Roll cage homologation by MSA-UK
- R** Light weight chassis painting
- R** Floor tunnel redesign for lower and centered seat position
- R** Extensive modification on wheel arches for lowered setup
- R** Left hand guide only
- R** Endurance ready chassis

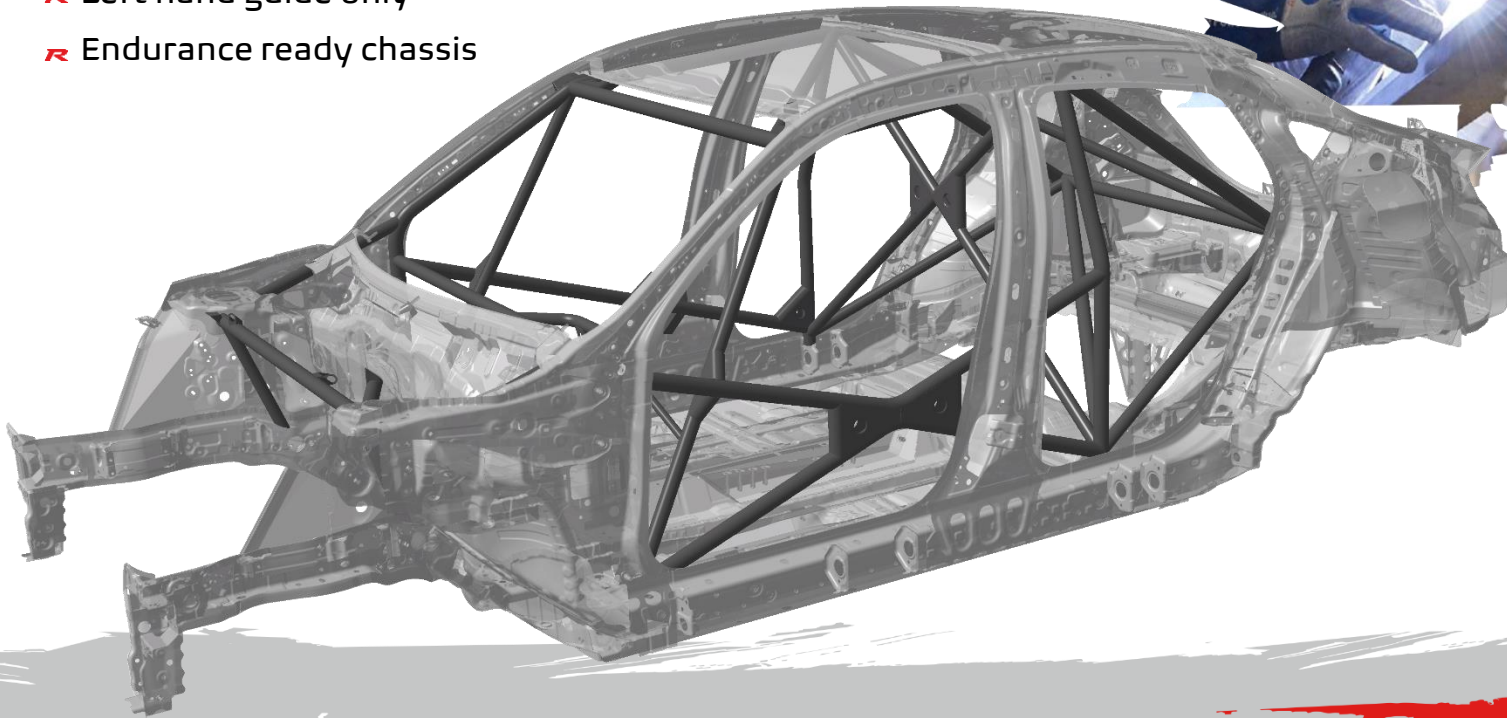

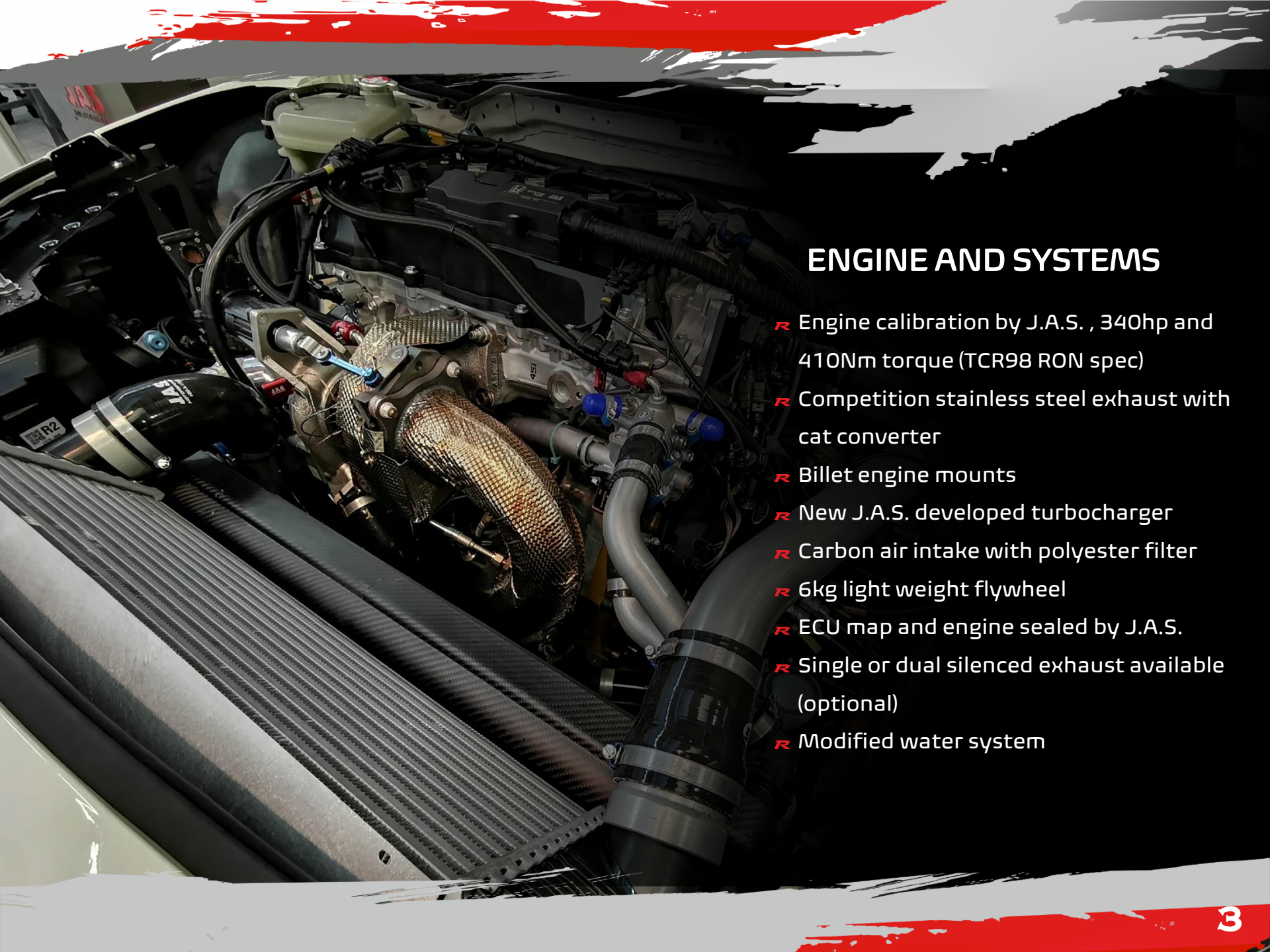

## ENGINE AND SYSTEMS

- R** Engine calibration by J.A.S. , 340hp and 410Nm torque (TCR98 RON spec)
- R** Competition stainless steel exhaust with cat converter
- R** Billet engine mounts
- R** New J.A.S. developed turbocharger
- R** Carbon air intake with polyester filter
- R** 6kg light weight flywheel
- R** ECU map and engine sealed by J.A.S.
- R** Single or dual silenced exhaust available (optional)
- R** Modified water system

## ENGINE CONTROL

- R MARELLI SRG141 Ecu with JAS calibrated maps
- R Fuel pressure sensors, lambda, MAP sensor, water and oil pressure/temperature sensors, active knock control and ETB installed on engine
- R Pit speed limits adjustable by steering wheel
- R Launch control
- R Cruise control

## HARNESSES

- R MoTec PDM30 powerbox
- R Custom engine harness DR25 protected with anti vibration reinforcement

## DISPLAY and DATA LOGGING



Motec C127 7"dash/logger with bespoke J.A.S. Interface including:

- R** Engine water, inlet, ambient temp
- R** Engine RPM, boost
- R** Gearbox oil temp, gear shift unit pressure, gear position
- R** Fuel DI and transfer pressure
- R** Fuel pressure
- R** Front/rear brake pressure
- R** Live brake bias
- R** Steering angle
- R** Sensors diagnostic
- R** Driver shift lights
- R** Led alarms on display
- R** Lat/long G-force sensor
- R** Split times on dash, with gain/loss
- R** Fuel consumption
- R** ODOmeter

### Optional

- R** I2 PRO logging
- R** J.A.S. analyzing Template
- R** Damper potentiometers
- R** Yaw sensor



## GEARBOX

- R** NEW Sadev ST90-17 6speed sequential Gearbox, with integrated actuator for paddle shift mechanism
- R** NEW hydraulic Sadev pressure unit
- R** NEW J.A.S. 3 Discs 184mm sintermetallic clutch
- R** Lightweight billet supports
- R** Easy cluster removal
- R** Adjustable preload from outside

### Optional

- R** Various homologated ramps
- R** Quick disconnect clutch line

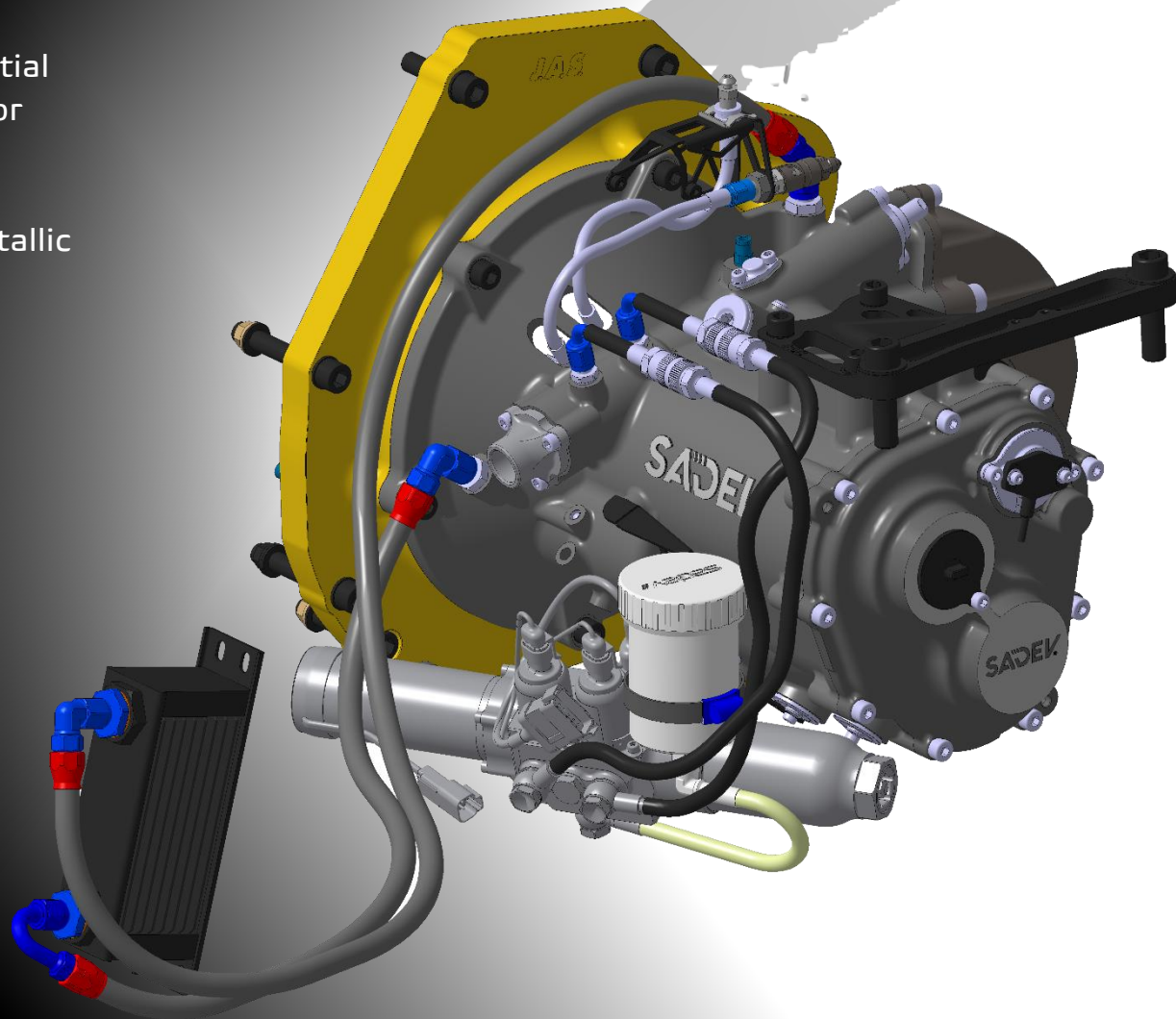



**JAS**

## FRONT SUSPENSION

- R** NEW damper strut co-engineered with KW Automotive
- R** NEW JAS design monoblock 6 pot calipers on 380x34 D54 discs
- R** Increased brake pads friction area
- R** NEW O.Z. Racing cast aluminium 18x10 rims
- R** NEW quick ratio electrical power steering system
- R** Heavy duty ball joints on all suspension pivot points
- R** Highly mass / stiffness optimized billet control arms and upright
- R** Heavy duty wheel studs (M14)
- R** Front quick change anti roll bars (3 position adjustable)
- R** Fully adjustable suspension kinematics parameters (camber, roll center high, antidive/antilift)

**JAS**  
MOTORSPORT

## REAR SUSPENSION

- R** NEW rear damper KW Automotive with quick stroke adjuster
- R** NEW Multilink rear suspension concept
- R** NEW O.Z. Racing cast aluminium 18x10 rims
- R** Heavy duty ball joints on all suspension pivot points
- R** Highly mass / stiffness optimized billet arms
- R** Heavy duty wheel studs (M14)
- R** 2 pot forged rear brake calipers with solid 260x9 discs
- R** Fully adjustable suspension kinematics parameters (camber, roll center high, static and dynamic toe, camber gain)



## BRAKING SYSTEM

- R** NEW Tilton floor mount pedalbox with high accuracy bias system
- R** NEW Monit brake bias with display mounted on steering column
- R** High efficiency Tilton Master cylinders
- R** Hydraulic handbrake «rally style»
- R** Lever Ap Racing pressure limiter
- R** Foot rest available (optional)
- R** Heel stop available (optional)

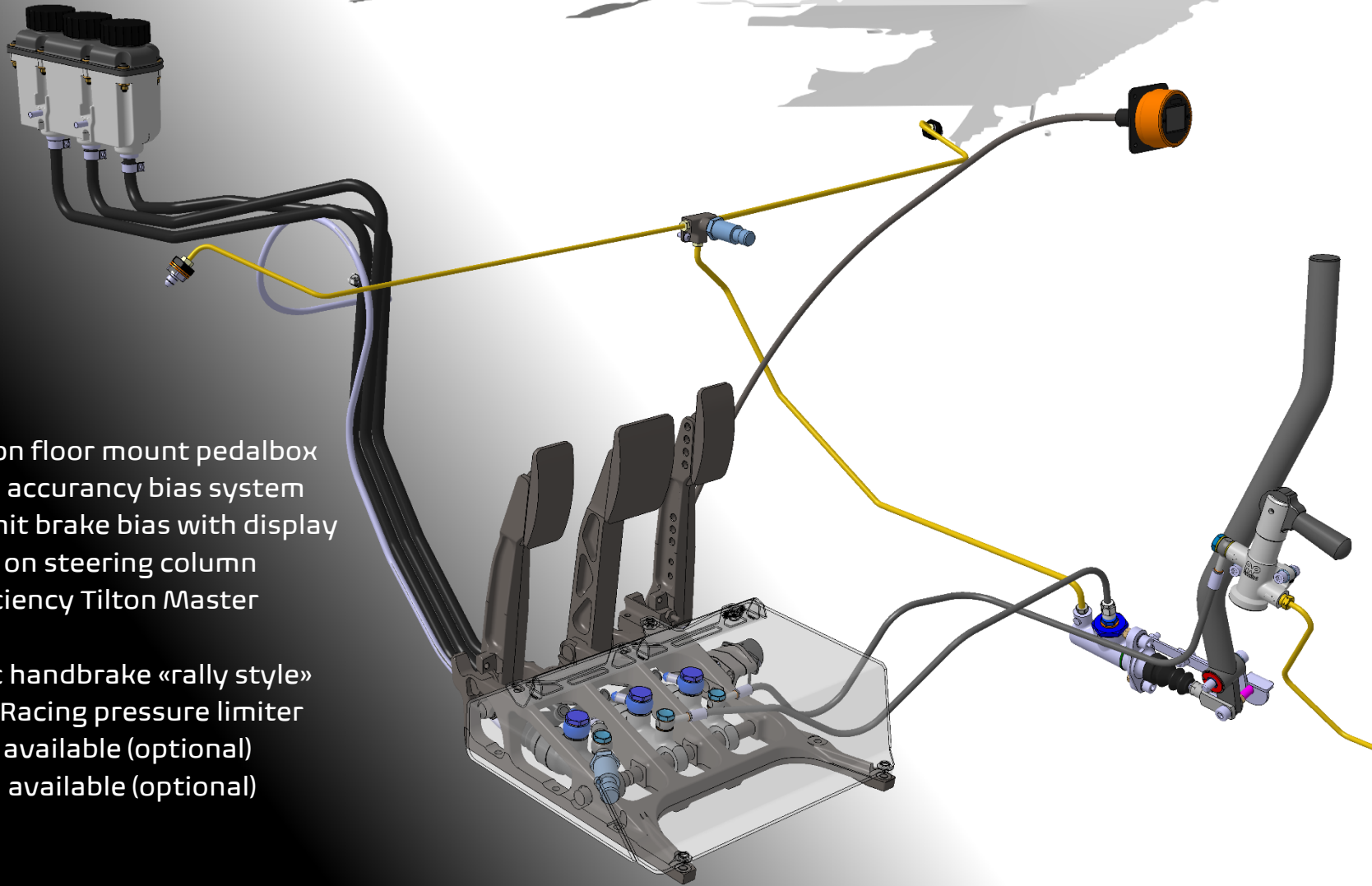

## FUEL SYSTEM

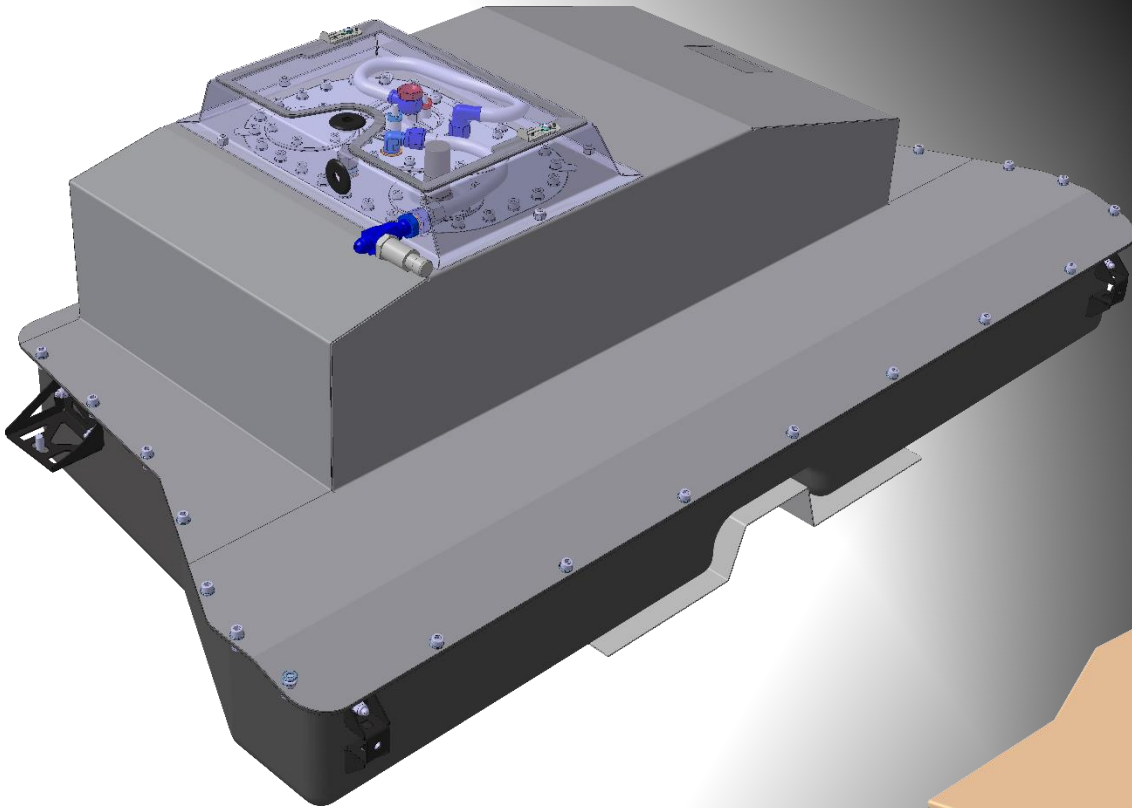

- R* NEW FT3 bladder 100lt without lift pumps
- R* No fuel return from engine to tank
- R* Aerospace quality hoses and fittings
- R* Lightweight carbon / aluminium covers

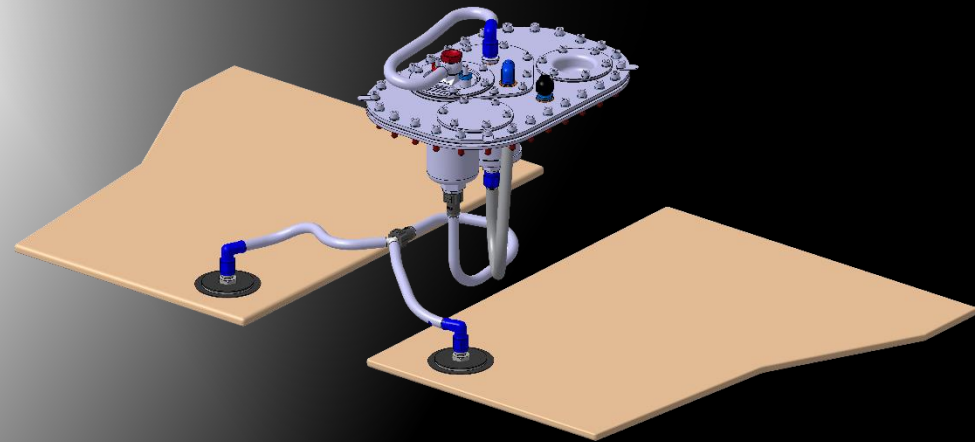

A close-up photograph of a black racing boot. The boot is positioned diagonally, with the toe pointing towards the upper right. On the side of the boot, the text 'JAS' is printed in large, bold, red letters with a white outline. Below 'JAS', the word 'MOTORSPORT' is printed in smaller, white, sans-serif capital letters. The background is a blurred view of a race track, showing a grid of white lights and a dark surface. The image is framed by a white border with red brushstroke-like accents at the top and bottom edges.

**JAS**  
MOTORSPORT

## INTERIOR EQUIPMENT

- R** NEW steering wheel co-engineered with cube controls: 16 frontal (RBG illuminated), 2 back buttons, 2 shifting paddles, 2 rotary switches (scroll and ABS levels)
- R** High grip handlers
- R** Steering column mounted switch panel
- R** NEW Heavy duty (38mm shaft) Air jack lifting system (2 front / 1 rear), GT style trunk plug
- R** Front and rear lightweight plastic door panels
- R** Custom made plastic dashboard
- R** OMP 6-point, 3" seat belts, for HANS use
- R** OMP seat Hte-EVO fiberglass with ear protection
- R** Lifeline automatic fire extinguisher
- R** LiFePo4 lightweight Battery
- R** Driver window safety net
- R** Wide angle rear view mirror

**J.A.S.**  
MOTORSPORT





## INTERIOR EQUIPMENT (optionals)

- R** 8862 and 8855-2021 seat and brackets available
- R** Lightweight carbon 8855 seats available in different sizes
- R** Passenger seat installation
- R** Racing net OMP or Safecraft
- R** Front lexan heated windscreen
- R** Ballast blocks (all the same shape except trunk)
- R** Drink system
- R** Pedalbox footrest

CIVICTOR

## ENDURANCE BRAKES (optional)

- R** Bosch M5 ABS system
- R** 12 anti locking setting with rotary switch on steering wheel
- R** Rear pressure limiter knob version installed for balanced braking also with ABS Off
- R** Quick brake change during pit-stop available

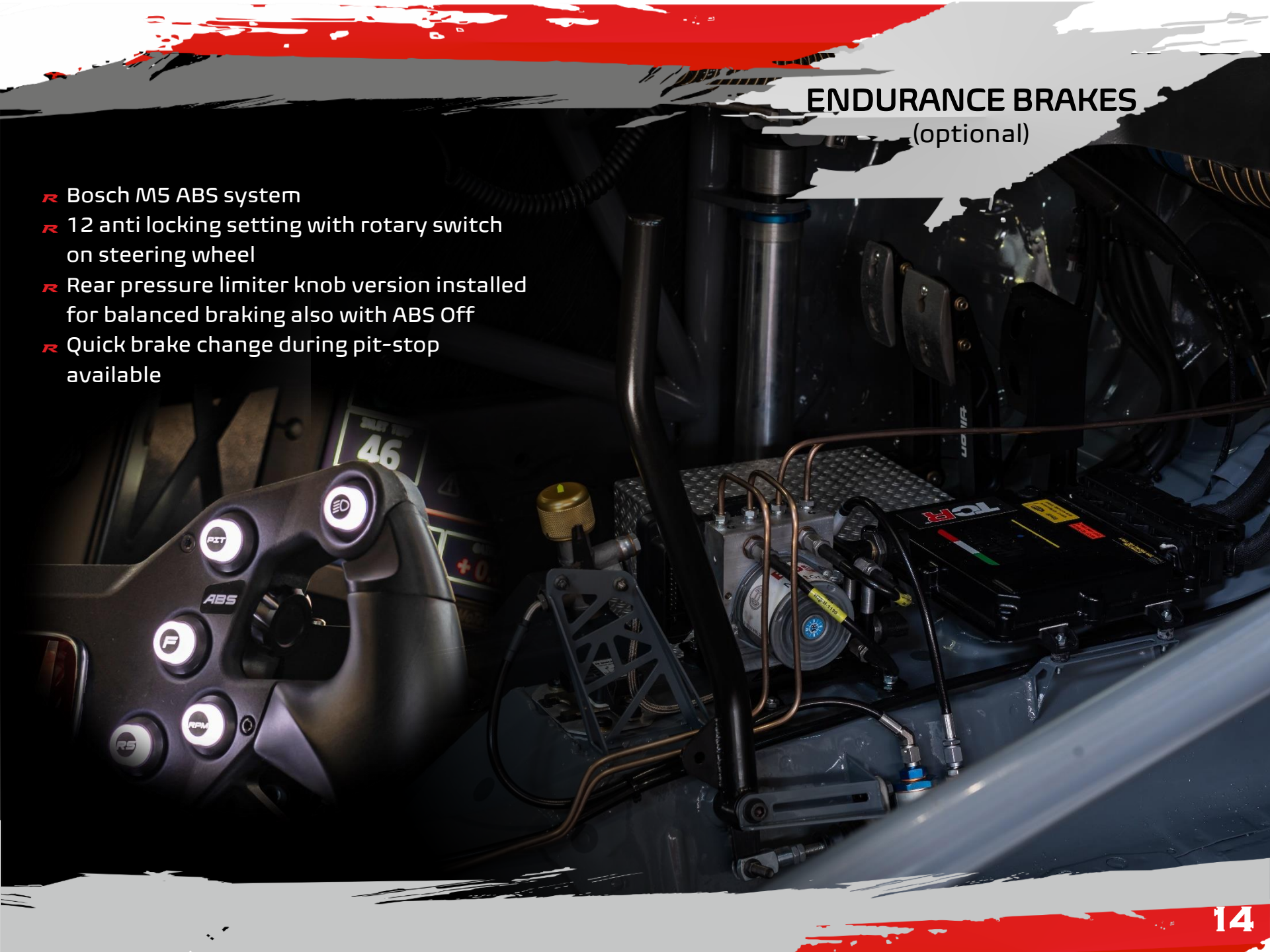



## ENDURANCE FUEL SYSTEM (optional)

- R** FIA twin filler neck (RH or LH mounting available)
- R** VLN style with capless plug available

# DRIVER OVERALLS BESPOKE CAR LIVERY



J.A.S. Motorsport can offer all teams the possibility to order bespoke driver overall in TCR design with driver name and sponsors on

New Civic cars can also have a customized livery upon request



## SERVICES

### Training at JAS Motorsport

The Customer is allowed to send one or more of his technicians and/or mechanics to assist and contribute to the final assembly of the car, for training purposes.  
The suggested duration of the training is one week before shake down.  
Travelling and accommodation of this personnel is at Customer charge.  
This service is highly recommended to new Customers.

### Technical Hot line

J.A.S. Motorsport may assist their Customers with technical issues or set-up questions through our Customer hot line via phone or, if needed, we can connect to our Customers car through the internet via «Team viewer».

### Technical assistance on sight

Upon request, JAS Motorsport may assist their Customers during the test session or race events worldwide.  
Skilled technicians will help the Team to familiarize with the car, to adapt the best set-up and troubleshoot technical problems.

### Spares

J.A.S. Motorsport have 800 square meters of warehouse, with two store and people that quickly react on any demand on spares request from our Customers worldwide.

## SERVICES

### Race Engineer

J.A.S. Motorsport offers to all customer race engineer service during testing or races, from one race to hole season basis; this service need to be booked in advance.

Customer will pay a daily fee for this service:

Working Days is 715,00€

Travel days is 540,00€

We do also make a complete "package" for complete season support as a fixed price.

### Race technician

J.A.S. Motorsport offers to all customer services as mechanics, gearbox technicians and electricians during testing or races, from one race to hole season basis; this service need to be booked in advance.

Customer will pay a daily fee for this service:

Working Days is 495,00€

Travel days is 385,00€

We do also make a complete "package" for complete season support as a fixed price.

### Driver Coach

J.A.S. Motorsport can offers to all customer driving coaching during testing or during race week-end in order to support driver/team to prepare the best possible way.

This service has to be booked in advance and will be charged with a daily fee.

## SALE CONDITION

**Honda Civic TCR based on FL5 Type R** as complete race ready car including Sadev sequential gearbox with hydraulic paddle shift, Honda K20C1 TCR engine, Marelli TCR ECU, Motec dash with data logging , KW 2 ways + blow off dampers, 10x18" O.Z. racing rims, composite bodywork painted, stainless steel exhaust, 100lt FT3 fuel tank

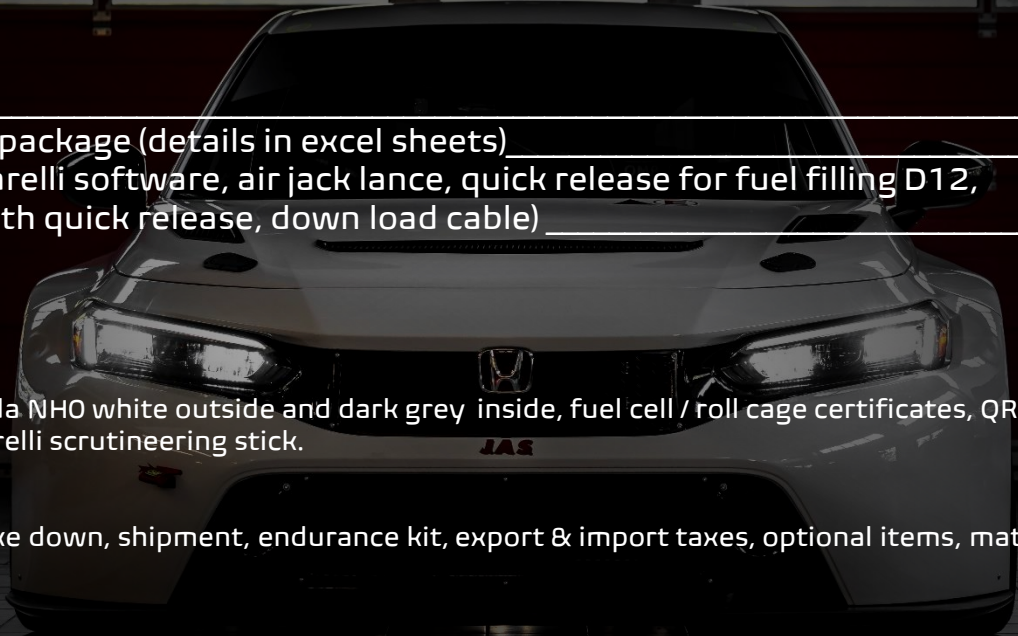

○ Sprint Car	156.000€
○ Initial spare part package (details in excel sheets)	15.000€
○ Initial tool kit (Marelli software, air jack lance, quick release for fuel filling D12, fuel drain pipe with quick release, down load cable)	1.950€

### Price included:

car assembly, colour Honda NHO white outside and dark grey inside, fuel cell / roll cage certificates, QR homologation form (online registration by team), Marelli scrutineering stick.

### Price not included:

Marelli Dongle, tools, shake down, shipment, endurance kit, export & import taxes, optional items, material for container loading in J.A.S. .



**J.A.S.**  
MOTORSPORT

J.A.S. Motorsport s.r.l.  
Via Guido Rossa 1/A - 20004 ARLUNO MI (ITALY)  
Tel. +39 02 90 37 541

[customerservice@jasmotorsport.com](mailto:customerservice@jasmotorsport.com)  
[www.jasmotorsport.com](http://www.jasmotorsport.com)



**HRC**  
Honda RACING

